

Articulated jib crane manipulator 2RM

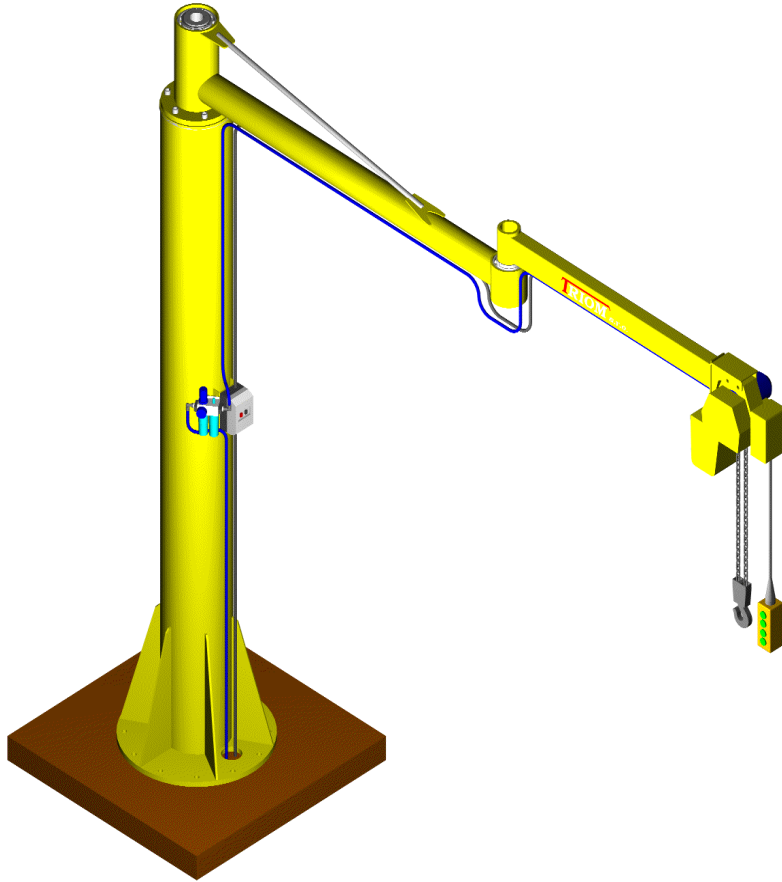

Utilization:

To manipulate with loads inside production and storage halls by using a hung hoist with the special hangers.

Advantage: easy manipulation in limited spaces - can reach around the corner, has maximum utilization of lifting in low-headroom spaces.

Technical description of the basic version:

The first beam of a circular profile is fixed to the ball bearings shaft that is attached to a swing bed which balances the axis of the beam to prevent it from spontaneous and unwanted rotation.

The second beam of a rectangle profile is articulated to the first arm from above or from below. There is the hoist hung at the end of the second beam. The adjustable hardstops on the shaft flange are used to prevent the first beam to spin 360° around or to set the specific workspace.

The column of the manipulator is provided with three standard heights – 2100 mm, 2600 mm, 3100 mm. Standard summary length of both beams – 2000 mm, 2500 mm, 3000 mm. On special requests also other sizes of the column or the beams can be made. The rotating beam can be mounted on a columns, walls or overhead fixed.

Basic technical specification:

Load capacity :	125 kg, 250 kg, 350 kg
Reach (mm):	2000 mm, 2500 mm, 3000 mm, 3500 mm
Weight of manipulator:	50 – 250 kg (by version)
Label:	2RM-(load capacity)-(reach)-(equipment)
Example:	2RM-125-2500-E(R)P (Elektro, (manual), Pneu)

Optional equipment:

- E** - Electrical installation 400 V with power switch and cabling
 - Hoist **GIS** or **Demag** with load capacity of 125, 250, 350 kg
- R** - Without electrical installation, e.g. chain handling of the hoist
- P** - Pneumatic components with closing valve and the filter of the compressed air.

Articulated jib crane manipulator 2RM 125 E /3500
with electric hoist DEMAG DCM

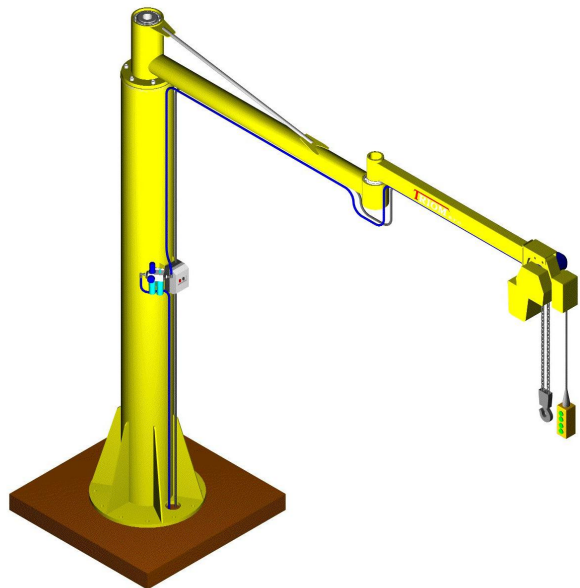

Realization:

Terex Material Handling s.r.o. pro NEMAK CR, Havraň 2015

1+1 ks

Articulated jib crane manipulator 2RM 125 E /3000
with the electric hoist and the hanging C-hook

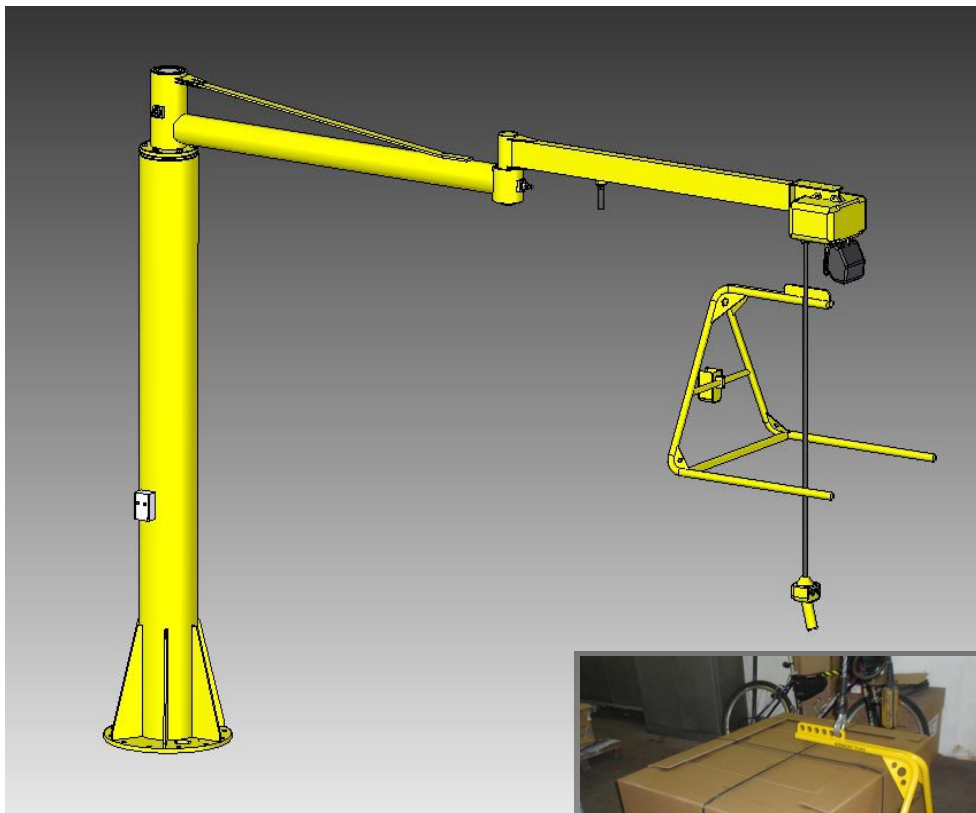

Realization:
MAHLE Behr Ostrava s.r.o.

2014

1 ks

Articulated jib crane manipulator 2RM 125 EP /3500 with the electric hoist and the frame with vakuum suction heads

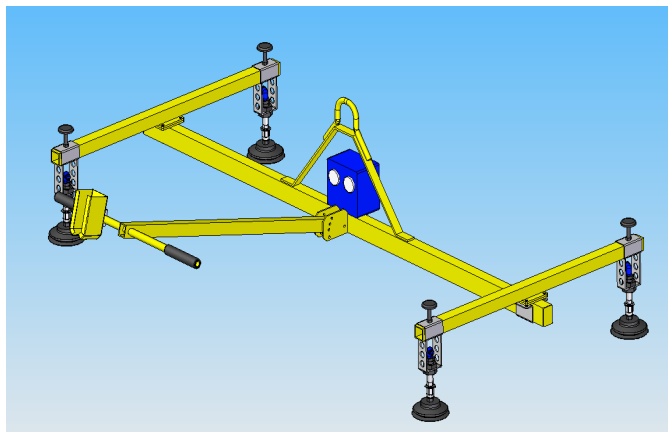
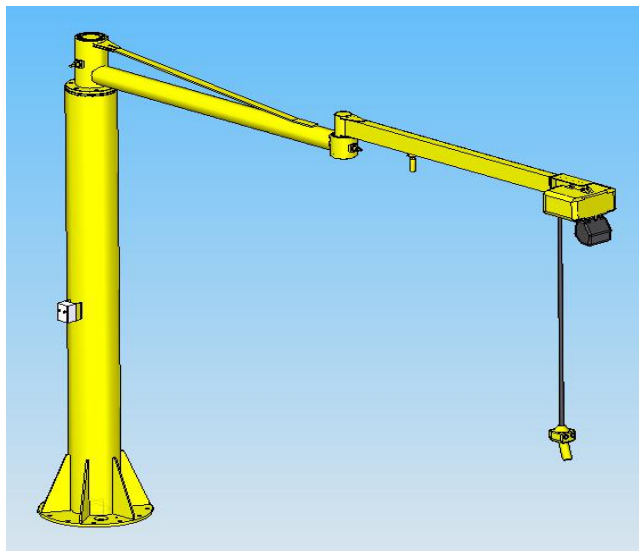

Realization:

Družstvo truhlářských služeb, Milenov

2012

1 ks

**Articulated jib crane manipulator 2RM 125 E /3000
with the electric hoist and the turning end effector**

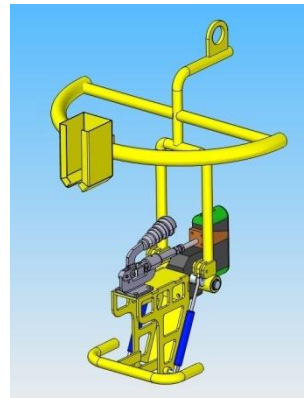
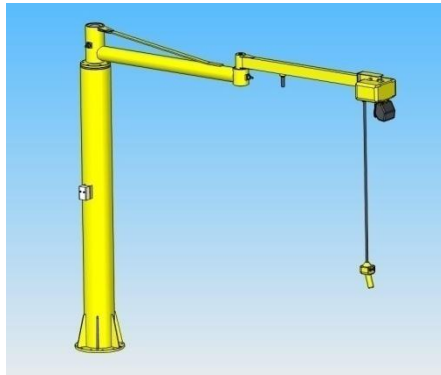

Realization:
Bosch Termotechnika, Albrechtice

2011

1 ks



Realization:
Iveco Czech Republic a.s., Vysoké Mýto

2007

23 ks

**Overhead fixed articulated jib crane manipulator 2RM
200 E /2500 with the electric hoist**

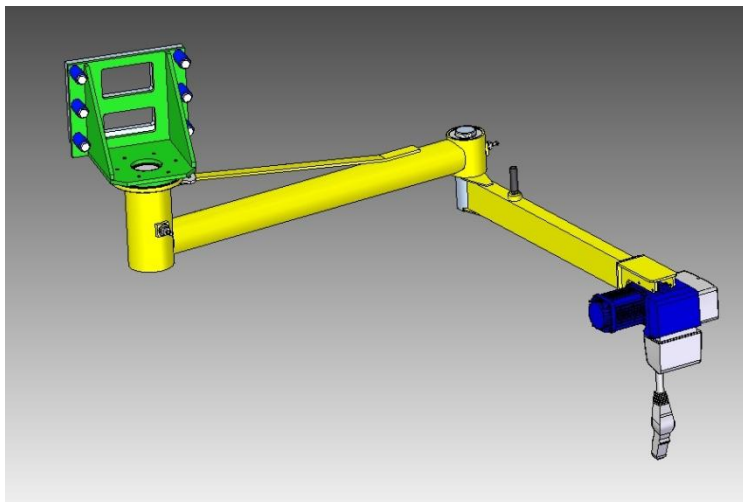

Realization:
DT Výhybkárna a strojírna a.s., Prostějov

2014

1 ks

Articulated jib crane manipulator 2RM 250 /3500
with the electric hoist



Realization:

Hydroscand Service s.r.o., Odry
Taforge, a.s., Kopřivnice

2015
2015

1 ks
1 ks

Articulated jib crane manipulator 2RM 250 /3500
with the electric hoist

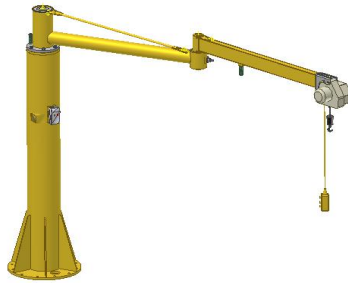

Realization:

Iveco Czech Republic a.s., Vysoké Mýto
RECUTECH s.r.o., Staré Hradiště

2009
2013

2 ks
1 ks

TRIOM s.r.o.

Articulated jib crane manipulator 2RM 250 E /3500 with the electric hoist and with the hook and the disconnecting end effector

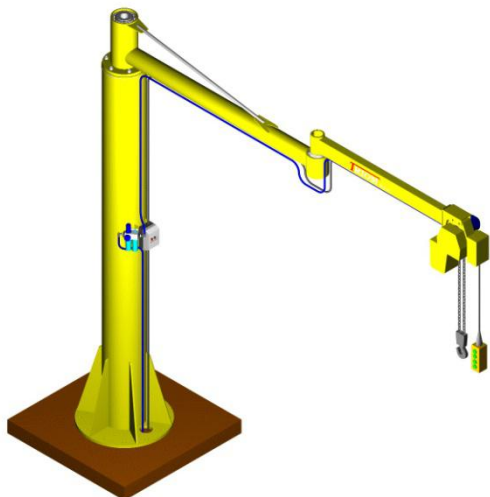

Realization:

Fa Semperflex Optimit s.r.o., Odry

2007

1 + 1 ks

**Overhead fixed articulated jib crane manipulator 2RM
250 E /2500 with the electric hoist**

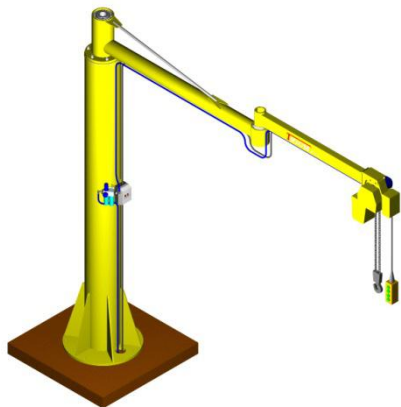

Realization:

STORI MANTEL, Rožnov pod Radhoštěm

2007

1 ks

Overhead fixed articulated jib crane manipulator
2RM 250 E /3500 with the electric hoist

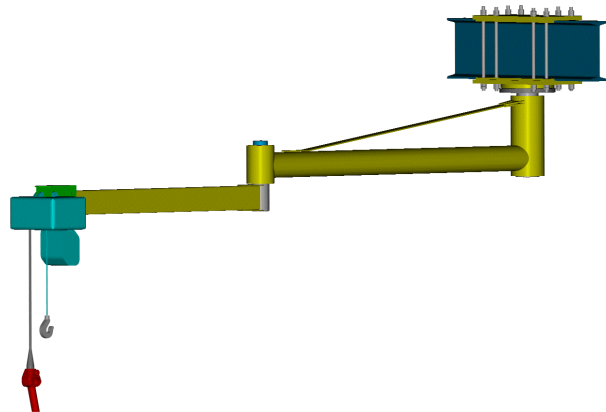

Realization:
Prostějovské strojírný

2007

1 ks

Articulated jib crane manipulator 2RM 250 EP /3500
With the electric hoist and the hanging C-hook

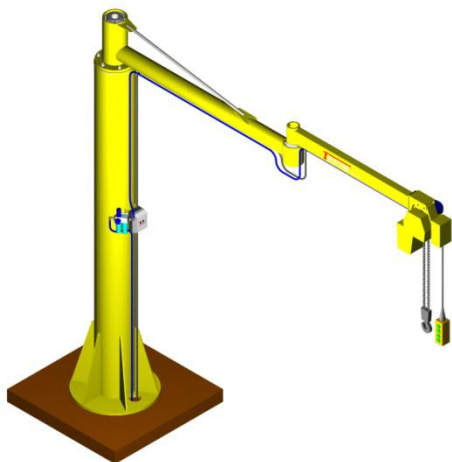

Realization:

Fa Semperflex Optimit s.r.o., Odry

2004, 2014

3 + 2 ks

Articulated jib crane manipulator 2RM 250 EP /3500 with the electric hoist and the frame with suction heads VZR 250

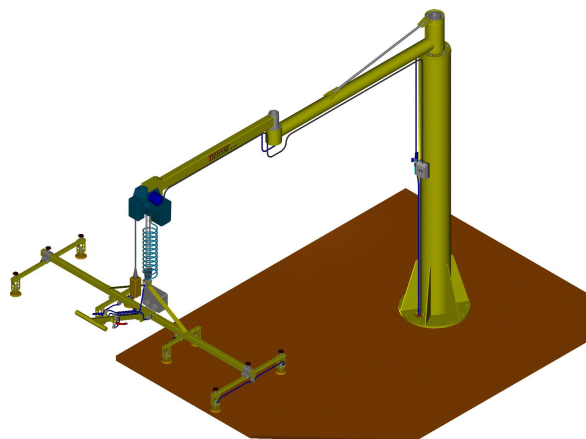

Realization:

Fa Matušík Josef, Prostřední Bečva

2003

1 ks

Articulated jib crane manipulator 2RM350/3000
with the electric hoist

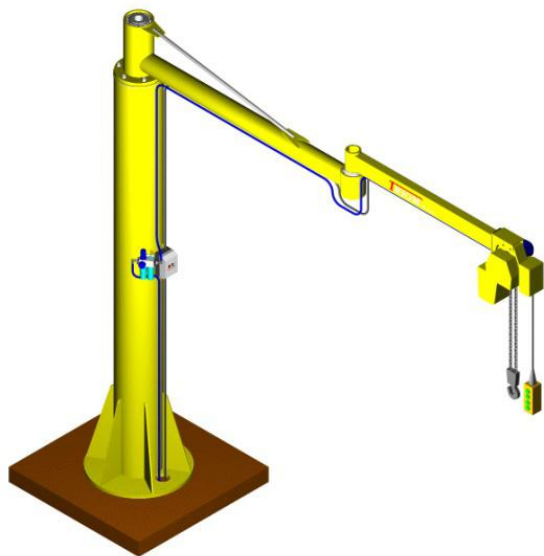

Realization:
INPEX pro f. UNIKOV, Martin, SR

2014

1 ks

Articulated jib crane manipulator 2RM 350 EP /4000
with the electric hoist and the frame with suction heads



Realization:
Hestego, Vyškov

2008

1 ks

Articulated jib crane manipulator 2RM350/3500 with the electric hoist and the frame with suction heads VZR 300

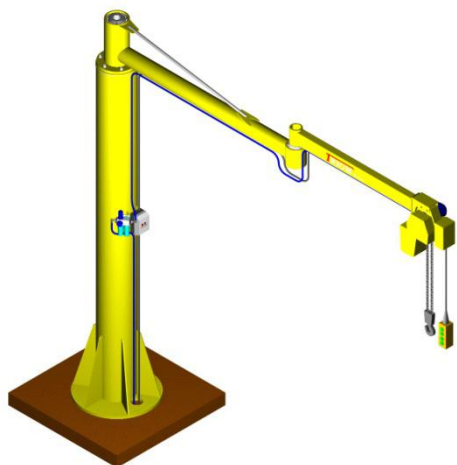

Realization:
Lasmetal s.r.o., Vyškov

2007

2 ks

Articulated jib crane manipulator 2RM 125 E
with the electric balancer LIFTRONIC EASY E 125

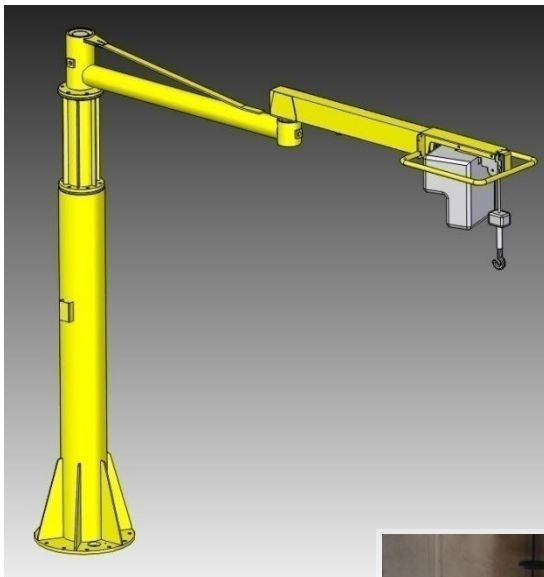

Realization:
SURFIN pro Transroll, Lednice

2015

2 ks

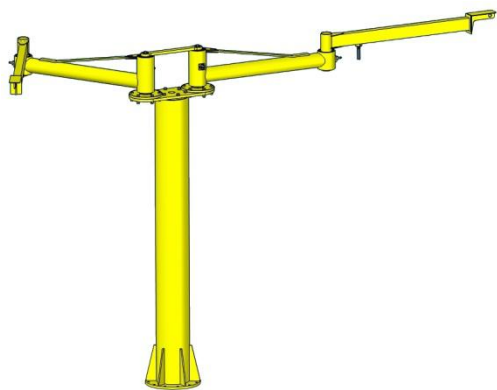

Realization:
Fa REMAK a.s., Rožnov pod Radhoštěm

2010

2 ks

TRIOM s.r.o.

**Double articulated jib crane manipulator 2x2RM 250 E /3000
with electric hoists**

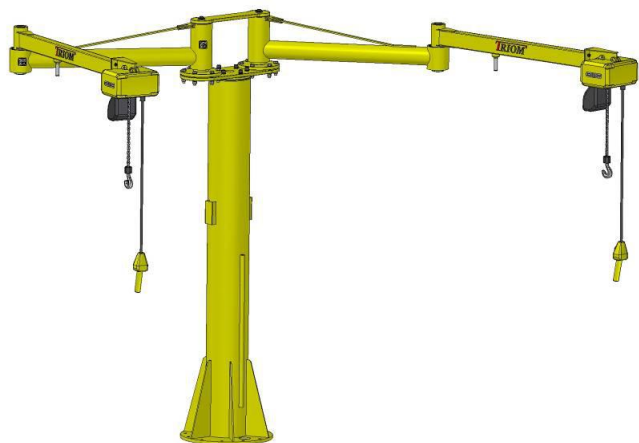

Realization:

Fa Graziano Trasmissioni Czech s.r.o, Červený Kostelec

2008

2 ks

TRIOM s.r.o.

Double articulated jib crane manipulator 2x2RM 250 E /3000
with electric hoists and the disconnecting end effectors

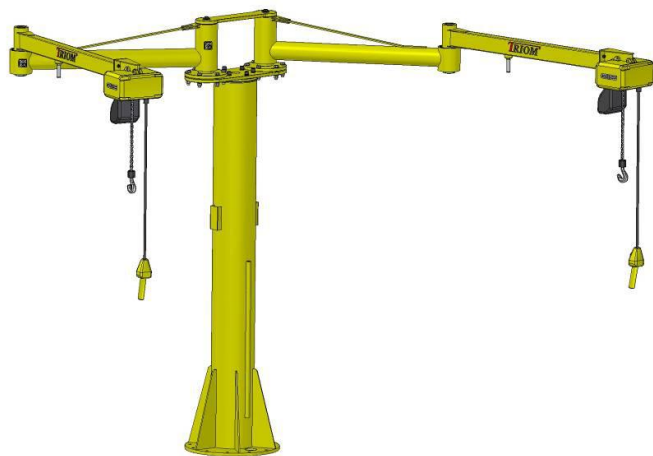

Realization:
fa Semperfex Optimit s.r.o., Odry

2007

1 ks